

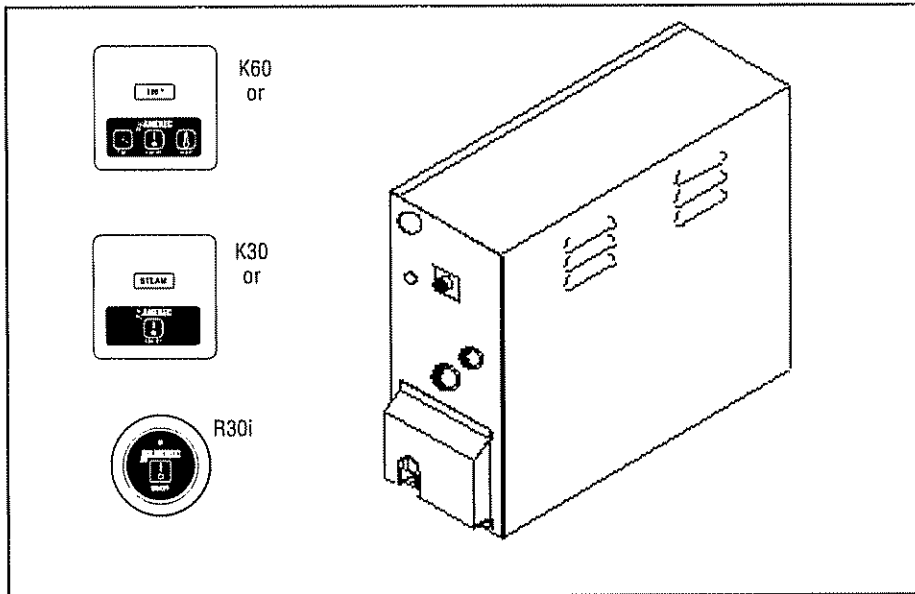

AMEREC™

3K Series Installation and Service Instructions



AMEREC STEAMBATH GENERATORS (MODELS: 3K-8, 10, 12, 14)

Note: To be used with R30i, K30 or K60 Control.

SAVE THESE INSTRUCTIONS

READ ALL INSTRUCTIONS CAREFULLY BEFORE INSTALLATION.

POST "STEAMBATH INSTRUCTIONS" LABEL OUTSIDE STEAMBATH FOR SAFETY WARNINGS.

SECTION 1: GENERAL INFORMATION

AMEREC Steam Generators are listed by Underwriters Laboratories. The steam generators come assembled and ready for installation. Check that the size and rating of the generator is suitable for your application, refer to Steam Room Construction and Generator Sizing Guide (AMEREC document 4211-33).

IMPORTANT

An exhaust fan installed outside the steam room is strongly recommended to remove excess steam from the bathroom or shower area.

WARNING

Electrical grounding is required on all AMEREC Steambath Generators.

All electrical supplies should be disconnected when servicing generator.

All wiring must be installed by a licensed electrical contractor in accordance with local and national codes.

All plumbing must be installed by a licensed plumber in accordance with all applicable local and national codes.

3K series generators are for indoor use only.

3K series generators are not for space heating purposes.

Be certain that steambath enclosures are properly sealed to avoid water damage from escaping steam. It is recommended that 100% silicone caulk be used to seal all pipes and fittings. Steam must be prevented from escaping into the wall cavity.

Never shut off the water to a steam generator that is in use.

Do not touch the steam head or trim during operation as they are hot. Stay at least 12 inches from the hot steam escaping from the steam head.

Electric Shock Hazard - High voltage exists within this equipment. There are no user serviceable parts in this equipment.



DIAGRAM 1

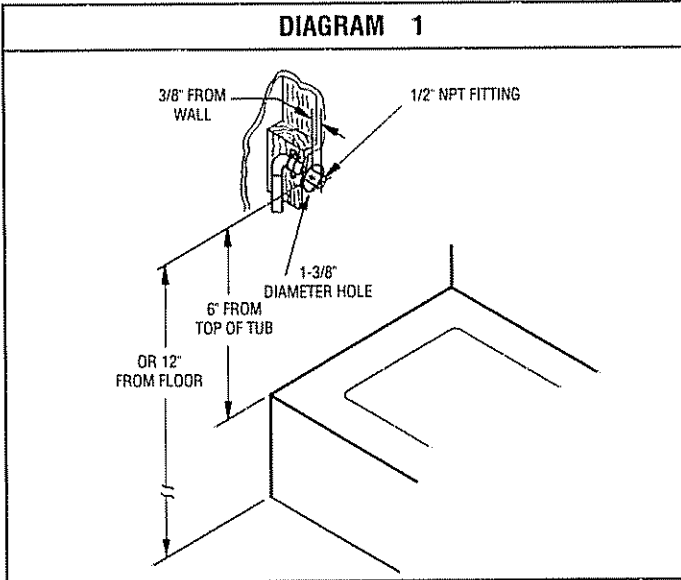

DIAGRAM 2

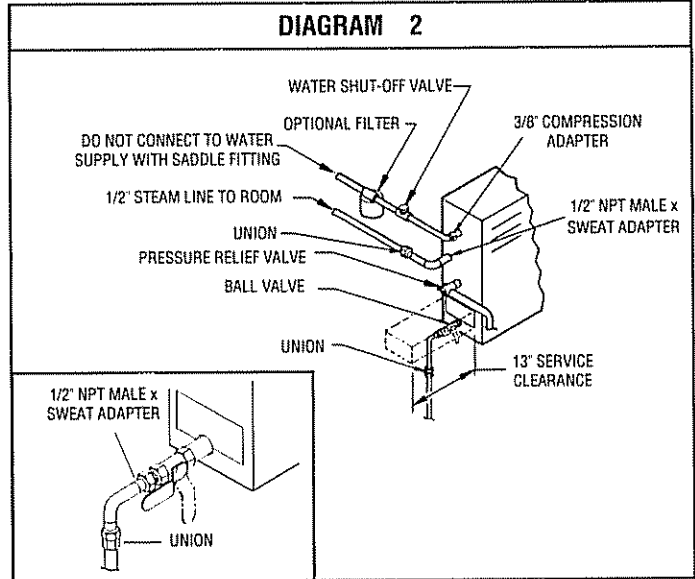
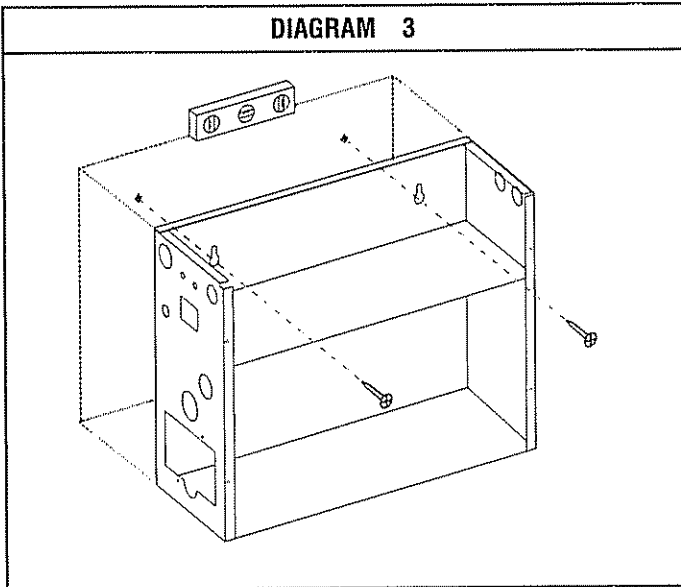

DIAGRAM 3





SECTION 2: SELECT MOUNTING LOCATION

SEE DIAGRAMS 1 & 2 ON PAGE 2

The AMEREC steam generator can be hung on a wall or sit on its base. The best mounting location will satisfy all or most of the following:

1. The steam line should slope to allow condensation to drain. Condensation should drain into the steam room.
2. The steam line should be less than twenty feet long. Ten feet is preferred. Steam lines over twenty feet long should be insulated.
3. The mounting location should minimize the number of bends and elbows in the steam line.
4. The generator should be installed in a dry, well ventilated area. Suggested locations are under a vanity, in a closet, attic, crawl space or basement.
5. The location should provide clearance for service and element removal. See diagram 2.
6. The mounting location should allow for a drain hook up.
7. The generator must be mounted in a minimum 7 cubic foot space.

SECTION 4: MOUNTING THE GENERATOR

SEE DIAGRAM 3 ON PAGE 2

Wall Mounting:

1. Note the location of the mounting holes on the back of the generator. The screws must set directly into studs or equivalent supports. Drill pilot holes on 16" centers and install the two #10 1½" screws provided.
2. Carefully hang the generator on the two screws. Tighten the screws. Replace the front cover. Secure the front cover with six screws.

Floor Mounting:

1. In general the width of the unit allows it to sit on a shelf, across the ceiling joists or on a floor. The generator must be restrained from moving. Normally the piping will provide adequate support. If not, additional support must be provided.
2. All floor installed generators must have provision for routine draining of the tank.

SECTION 5: PLUMBING INSTRUCTIONS

SEE DIAGRAM 1 & 2 ON PAGE 2, 5 & 6 ON PAGE 4

All plumbing shall be installed by a licensed plumber and conform with local & national codes.

Materials (locally available):

- 3/8" O.D. copper tube for the water supply to the generator.
- 3/8" water supply shut-off valve
- 3/8" supply valve housing and filter (optional depending on local water conditions).
- 3/8" O.D. compression to 3/8" male NPT adapter.
- 1/2" copper sweat unions (2)
- 1/2" copper pipe for the tank drain.
- 1/2" copper pipe and 1/2" female NPT sweat adapter for the steam line between the generator and the steam room.
- 3/4" copper pipe, fittings, and a sweat union for the Pressure Relief Valve drain.
- Tube DAP 100% silicone caulk
- Rectorseal No 5 pipe compound

1. INSTALL WATER LINE

Run 3/8" copper tube between the nearest cold water line and the WATER INLET fitting on the generator. Locate a shut-off valve near the generator. Connect this line to the generator with a 3/8" compression adapter. When tightening this fitting always use two wrenches so there will be no strain on the water inlet valve.

IMPORTANT

If the generator is mounted in a place difficult for the home owner to access, the water supply shut-off valve should be located where it can be quickly accessed in an emergency.

IMPORTANT

Do not use a saddle valve or saddle fitting for the water shut-off valve. Flush water supply line before final hookup.

2. INSTALL STEAM LINE

A. At the generator: Install a 1/2" male NPT sweat adapter directly into the tank. Install a 1/2" union in the steam line.

B. Run the 1/2" copper steam line from the generator to the steam room. Refer to SECTION 2: SELECT MOUNTING LOCATION.

C. The steam line should enter the steam room 12" above the floor or at least 6" above a tub rim or ledge. See diagram 1.

D. At the steam room: Drill/prepare a 1-3/8" hole for the steam line entry. Center the 1/2" copper steam pipe in the 1-3/8" hole. See diagram 5.

- Terminate the steam line with a 1/2" NPT male adapter. Stub the line out into the room 3/8" from the finished surface.
- Secure the steam line to a structural member.

IMPORTANT

If the steam line is in an area where the temperature will be below 40 degrees Fahrenheit or if the line is more than 20 feet long, best results can be obtained by insulating the steam pipe.

WARNING

*Do not mount outdoors.
Protect from freezing.*

Unit must be located as to allow access for service.

The generator will not operate properly, unless it is mounted level with the arrows pointed up.

Do not put a shut off valve in the steam line. Avoid traps and valleys where water could collect and cause a steam blockage. The hot steam line must be insulated against user contact.

Centering the steam pipe is critical in rooms made of plastic, acrylic, resin, fiberglass or similar materials. Allowing the steam pipes to touch materials not rated for 212 degrees Fahrenheit or higher will result in damage to these materials.

Do not install the steam head near bench(es) or where steam may spray or where condensation will drip on the user as this will present a scald hazard.

The steam pipe entry and any other entry into the steam room must be caulked to avoid damage caused by steam leakage into the wall.

DIAGRAM 5

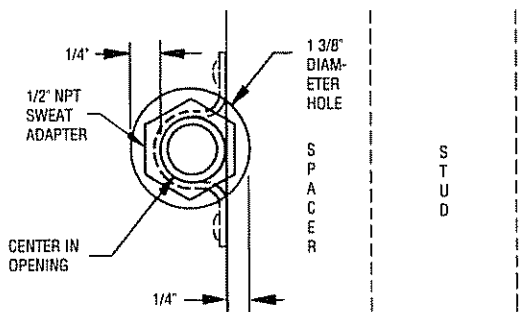

DIAGRAM 6

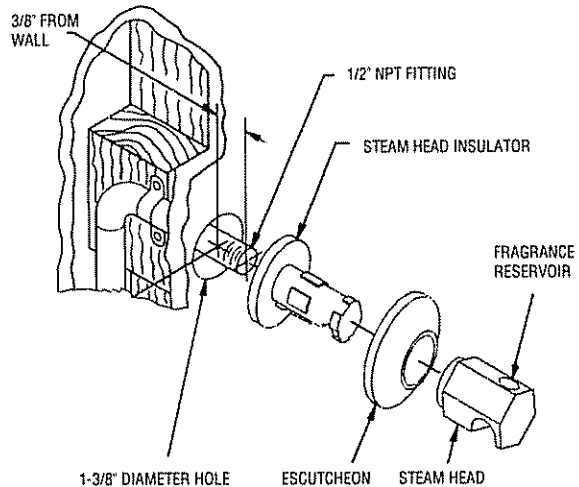

DIAGRAM 7

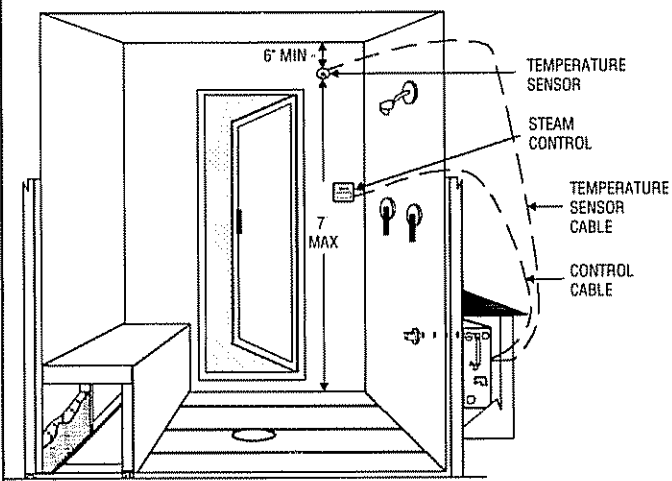

DIAGRAM 8

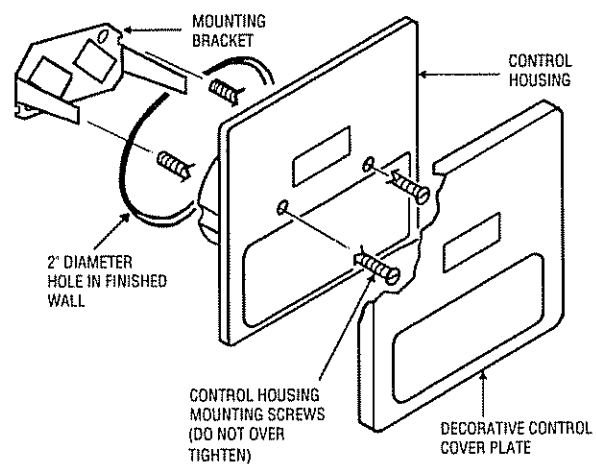

DIAGRAM 9

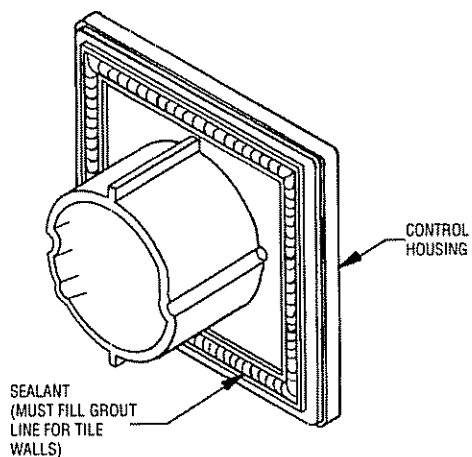
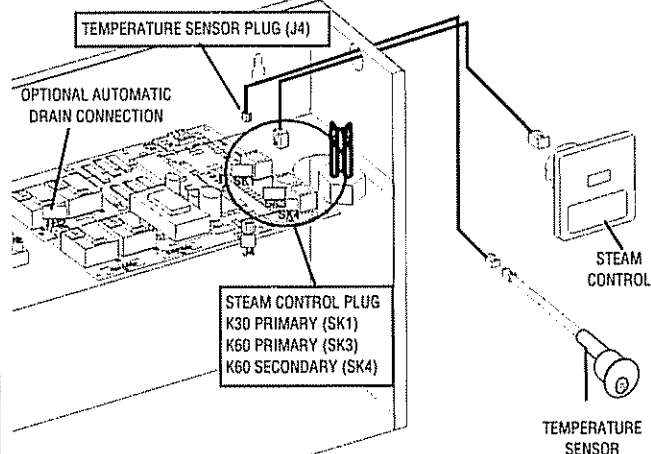

DIAGRAM 10



SECTION 5: PLUMBING INSTRUCTIONS (continued)

SEE DIAGRAM 2, 5 & 6 ON PAGE 4

3. INSTALL STEAM HEAD INSULATOR: Apply silicone caulk to the finished wall side of the steam head insulator and screw on hand tight until it is flush with the wall with the opening pointing down. If a hand tight fit does not align with the opening pointing down, use teflon tape on the steam line threads to adjust the fit

4. INSTALL STEAM HEAD AND ESCUTCHEON: Place the escutcheon over the steam head insulator then slide the steam head on until the escutcheon rests firmly against the finished wall. Tighten the hex head screw underneath the steam head to secure it in place with the allen wrench provided. The steam head should be level with its fragrance reservoir at the top. See diagram 6

IMPORTANT

Check all of the standard fixtures in the steam room. All fixture penetrations must be sealed with 100% silicon caulk to avoid moisture damage within walls

5. INSTALL PRESSURE RELIEF VALVE

Install the pressure relief valve into its port on the generator. The pressure relief valve outlet must drain in accordance with local and national codes

6. INSTALL DRAIN VALVE

Install 1/2" NPT male sweat adapter directly into the tank as shown in diagram 2. Install a 1/2" union. Run a 1/2" copper drain line to a gravity flow drain. Do not run the drain uphill. The drain must be connected in accordance with local and national codes. See diagram 2.

SECTION 6A: WIRING INSTRUCTIONS (W/K60 or K30)

SEE ELEC. INFO. CHART ON PG. 6 & DIA. 7, 8, 9 & 10 ON PG. 4, WIRING DIA. ON PG. 15

1. CONTROL CABLE ROUGH-IN

The low voltage control can be mounted up to 25 feet from the generator either inside or outside the steam room, also see #6 optional secondary generator control. String the 25' cable from the control location through 1/2" holes in the wall studs or ceiling joists to the generator. Note: Do not staple through or damage cable. Use factory supplied cables only. Optional for tile rooms, a 1 gang rough-in box may be installed at the desired control mounting location. A mounting plate with proper 2" diameter hole is included with the control kit. Tile up to the 2" hole in mounting plate as indicated in diagram 14

2. TEMPERATURE SENSOR CABLE ROUGH-IN

It is recommended that the sensor be mounted in the steam room 6" from the ceiling, but not directly over the steam dispersion head or more than 7 feet above the floor. String the sensor cable from the sensor location through 1/2" holes in the wall studs or ceiling joists to the generator location. Leave 12" of slack at the sensor location. Note: Do not staple through or damage cable. Use factory supplied cables only

3. ELECTRICAL ROUGH-IN

Size wire for the generator as indicated by the Electrical Information Chart on page 6. Use correct size and type to meet electrical codes. Leave 4 feet of slack wire at generator location for finish hookup. Connect the generator to a dedicated circuit breaker. A GFI device is not required by UL. One may be installed if required by local codes or the owner. A GFI device will tend to nuisance trip due to heater element aging.

4. ELECTRICAL FINISH

Materials (locally available):
- 3/4" Strain relief for supply wire

- A. Route the copper supply wire with appropriate strain relief through the hole marked POWER ENTRY.
- B. Connect the supply wires to terminal blocks marked L1, L2 and L3.
- C. Connect the ground to the ground lug (green screw on junction compartment wall)

5. INSTALL GENERATOR CONTROL

The low voltage control can be mounted directly to a finished wall either inside or outside the steam room. Using a 2" hole saw, drill a hole in the finished wall where the control is to be mounted (the control cable should already be roughed-in to this location). Locate the control cable, pull it out through the 2" hole and plug it into the connector on the back of the control housing. With the decorative cover removed, screw the two 3" control housing mounting screws 1/4" into the mounting bracket. See diagram 8. Run a bead of 100% silicon caulk in-between the 2 ridges around the perimeter on the back of the control housing. See diagram 9. Insert the mounting bracket into the wall cavity by first pushing with the control housing and then with a hard flat surface on the control housing mounting screws which extend out through the control face. Once the mounting bracket has been inserted into the finished wall, center the control and tighten the mounting screws to draw the control housing securely against the finished wall. Do not over tighten the mounting screws. Install the decorative cover plate by sliding the top of the cover plate over the tab on the top of the control housing and pushing on the bottom of the cover plate to complete the snap fit. See diagram 11. Route the generator end of the control cable through the generator hole marked CONTROL WIRING ENTRY using the strain relief provided. Plug the control cable into the connector on the printed circuit board assembly. Insert cable into connector SK1 if a K30 control is used or connector SK3 if a K60 control is used. See diagram 10

6. OPTIONAL SECONDARY GENERATOR CONTROL

As an option, a second K60 control can be installed with an 3K generator to provide ON/OFF control both inside and outside the steam room. The second control should be installed as described in paragraphs 1 & 5, with the second control cable plugged into connector SK4 for the K60 Control on the printed circuit board assembly. See diagram 10

7. INSTALL TEMPERATURE SENSOR

The temperature sensor should be mounted 6" below the ceiling, inside the steam room, but not directly

(continued page 7)

WARNING

The pressure relief valve must be installed in such a fashion that the risk of scalding is reduced to a minimum. Draining the pressure relief valve into the steam room may present a scald hazard.

Boiling water may be discharged from the drain. Proper precaution should be taken to insure safety.

Draining the tank into the steam room may present a scald hazard and/or damage materials used to construct the steam room.

Electrical shock hazard - Disconnect all electrical power before servicing the generator. All wiring should be installed by a licensed electrical contractor in accordance with local and national codes.

The generator is designed for hookup with copper wire only.

continued

DIAGRAM 11

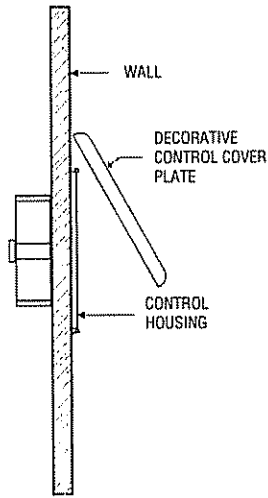
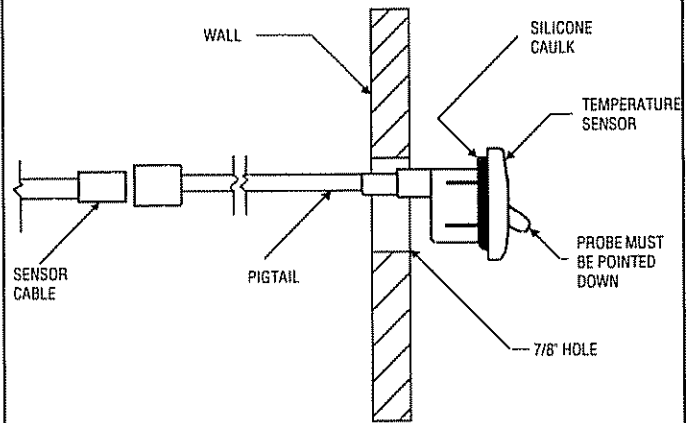

DIAGRAM 12



ELECTRICAL INFORMATION CHART

STEAM GENERATOR MODEL NO	AC VOLTAGE	PHASE	NOMINAL WATTAGE	NOMINAL AMPERAGE	RECOMMENDED PROTECTIVE DEVICE	RECOMMENDED MINIMUM COPPER SUPPLY WIRE*
3K-8	208	3	7,896	21.9	30	10-3 W/G
3K-10	208	3	10,140	28.1	40	8-3 W/G
3K-12	208	3	12,000	33.3	50	6-3 W/G
3K-14	208	3	14,464	40.1	60	6-3 W/G

* Observe wire sizes for 208 VAC installations. 208 VAC wired units must be supplied with a minimum of 195 VAC while operating (heating). Unit is rated for copper wire only. All wire is UL approved 300V 75 deg. C minimum unless otherwise specified.

DIAGRAM 13

This diagram intentionally left blank.

DIAGRAM 14

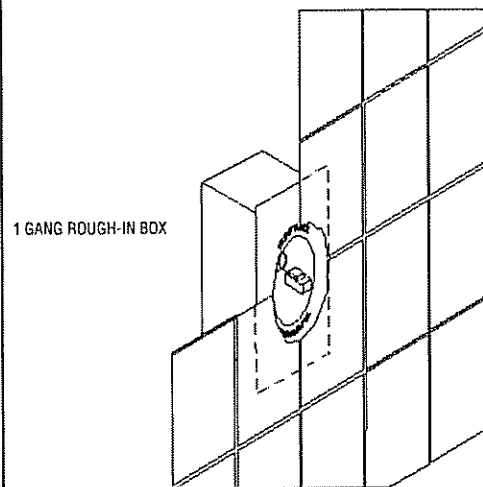

SECTION 6A: WIRING INSTRUCTIONS (W/K30 or K60) (continued)

SEE DIAGRAM 12 ON PAGE 6

over the steam dispersion head or more than 7 feet above the floor. Using a 7/8" hole saw, drill a hole in the finished wall where the sensor is to be mounted (the sensor cable should already be roughed-in to this location). Locate the sensor cable, pull it out through the hole and plug it into the temperature sensor. It is best to tape the sensor and cable connection together to avoid disconnection inside the wall. Apply silicon caulk as shown in diagram 12 and insert the sensor in the hole. See diagram 12. Make sure that

the sensor probe is pointing down once installed. Tape the sensor in place while the silicone hardens. Route the generator end of the sensor cable through the generator hole marked CONTROL WIRING ENTRY using the control cable strain relief. Plug the sensor cable into the connector marked J4 on the printed circuit board assembly. See diagram 10.

SECTION 6B: WIRING INSTRUCTIONS (W/R30i)

SEE ELEC. INFO. CHART ON PG. 6 & DIA. 15, 16, 17 & 18 ON PG. 8, WIRING DIA. ON PG. 15

1. CONTROL CABLE ROUGH-IN

The low voltage control can be mounted up to 75 feet from the generator either inside or outside the steam room, also see #6 optional secondary generator control. String the (3) 18 to 22 AWG solid wires from the control location through 1/2" holes in the wall studs or ceiling joists to the generator.

Note:

- 1) Do not staple through or damage wires
- 2) Label or color code wires for proper TB1 to R30i orientation. See diagrams 16 & 17.

2. CONTROL CABLE FINISH

Route control wires through the generator CONTROL WIRING ENTRY and appropriate strain relief. Connect (3) wires to terminal block TB1 on the printed circuit assembly as shown in diagram 17.

3. ELECTRICAL ROUGH-IN

Size wire for the generator as indicated by the Electrical Information Chart. Use correct size and type to meet electrical codes. Leave 4 feet of slack wire at generator location for finish hookup. Connect the generator to a dedicated circuit breaker. A GFI device is not required by UL. One may be installed if required by local codes or the owner. A GFI device will tend to nuisance trip due to heater element aging.

4. ELECTRICAL FINISH

Materials (locally available):

- 3/4" Strain relief for supply wire

- A. Route the copper supply wire with appropriate strain relief through the hole marked POWER ENTRY.
- B. Connect the supply wires to the terminal block marked L1, L2 and L3.
- C. Connect the ground to the ground lug (green screw on junction compartment wall).

5. INSTALL GENERATOR CONTROL (R30i):

The low voltage control can be mounted directly to a finished wall either inside or outside the steam room. Using a 1-3/4" hole saw, drill a hole in the finished wall where the control is to be mounted (the control wires should already be roughed-in to this location). Locate the control wires, pull them out through the 1-3/4" hole and plug the 3 wires into the connector on the back of the control housing, as shown in diagram 16. Run a bead of 100% silicone caulk around the perimeter on the back of the control housing. See diagram 18. Insert the control into the wall cavity.

6. OPTIONAL SECONDARY GENERATOR CONTROL:

As an option, a second R30i control can be installed with an AR generator to provide ON/OFF control both inside and outside the steam room. The second control should be installed as described in paragraphs 2 & 4, with the second control wire plugged into the same connector TB1 connector as the first R30i control.

WARNING

Electrical shock hazard - Disconnect all electrical power before servicing the generator. All wiring should be installed by a licensed electrical contractor in accordance with local and national codes.

For continued safe operation use factory authorized replacement elements only.

SECTION 7: OPERATIONAL TEST

1. Assure power and water are on.
2. Press the ON/OFF. The control should light-up.
3. Allow 10 minutes for the steam to start.
4. Once the steam starts, press the ON/OFF. The steam should stop; there shouldn't be any water flow. The control should not be lit-up.
5. Press the ON/OFF. The control should light up.
6. Within one minute the unit should again produce steam. It should call for water once every two minutes or more depending on its power rating. It's normal for

the flow of steam out the steam head to slow for up to 10 seconds each time the unit calls for water.

7. The unit will shut down automatically in 30 minutes if the R30i or K30 Control is used, or up to 60 minutes if the K60 Control is used. When the time runs out the steam will stop and there should not be any water flow. The control should not be lit.

8. If the unit does not operate as described above, refer to SECTION 10: TROUBLESHOOTING GUIDE.

THE UNIT IS NOW READY FOR OPERATION.

DIAGRAM 15 (R30i Control)

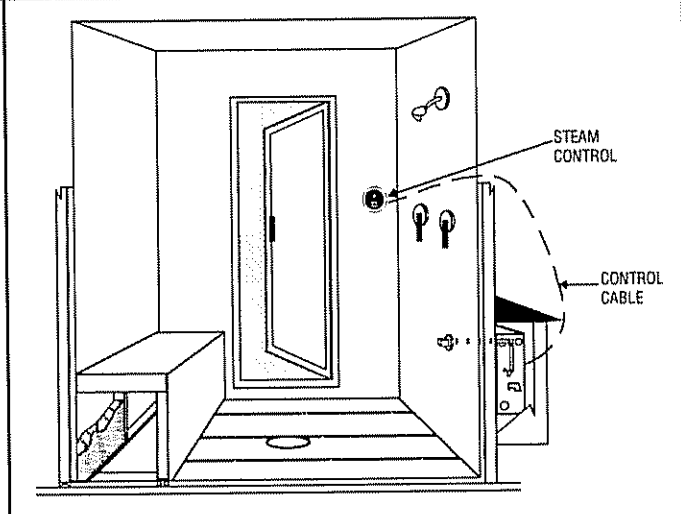

DIAGRAM 16 (R30i Control)

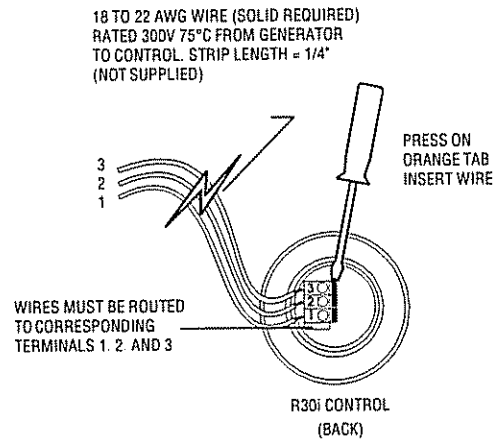

DIAGRAM 17 (R30i Control)

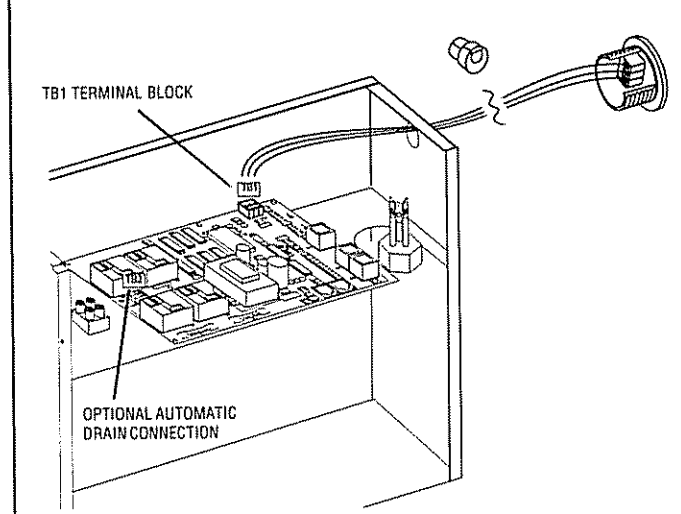
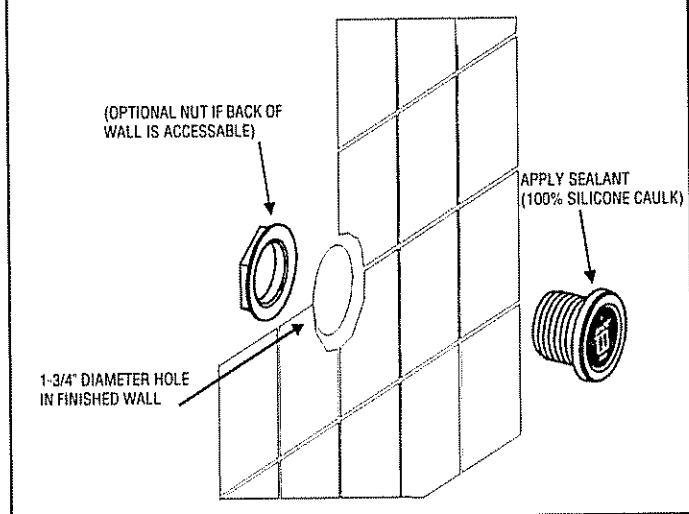

DIAGRAM 18 (R30i Control)



SECTION 8: SERVICE

SEE ELECTRICAL INFORMATION CHART ON PAGE 6

1. DESCRIPTION OF AMEREC 3K SERIES GENERATOR

The 3K series is one of AMEREC's high performance line of steam generator products. Electronic circuitry is used throughout to provide closed loop temperature control, soft steam element switching and a 30 or 60 minute timer

The Printed Circuit Assembly (the "PCA") provides the basic functions necessary to produce steam. The PCA controls makeup water, provides a water level permissive for powering the elements and provides raw DC power for the system

The PCA also provides regulated non-interruptible 5.0 VDC power for the generator control and temperature sensor. It provides the interface circuitry between the control and the PCA, provides the room temperature control loop, power switching for "soft steam" and a fixed 30 minute steam bath timer or adjustable 60 minute timer

2. MAINTENANCE OF 3K SERIES STEAM GENERATORS

- **VISUAL INSPECTION** - Whenever the generator is opened, inspect for any evidence of water leaks. Inspect the wiring for any evidence of overheating. Check all electrical connections for tightness

- **FLUSH TANK** - Flush monthly, or more often, depending on local water conditions

- FLUSHING PROCEDURE:

1. The generator should be cool
2. Press the ON/OFF. The control should light
3. Open the manual drain valve
4. The unit will drain without heating the water

5. Allow the water to run for a full 10 minutes, then press the ON/OFF. The control light should turn off.
- (continued page 9)

WARNING

Electrical shock hazard - Disconnect all electrical power before servicing the generator. All wiring should be installed by a licensed electrical contractor in accordance with local and national codes.

For continued safe operation use factory authorized replacement elements only.

SECTION 8: SERVICE (continued)

SEE DIAGRAMS 19, THRU 24

6. Allow the unit to drain completely. When the water stops, close the manual drain valve.

3. REPAIR OF 3K SERIES GENERATORS**A. ELEMENT REPLACEMENT:**

Disconnect power from the unit. Drain the tank. Open the front and HEATING ELEMENT ACCESS covers. Note the wire connections. See diagram 19. Remove the element wires. Using a hot water element socket, remove the element. To install a new element, mount a new element gasket on the element. Clean the element port and add a light coat of Rectorseal No. 5 pipe thread compound to the threads. Insert and hand tighten the element-gasket combination. Notice the element end orientation as shown in diagram 20. Tighten the element until the orientation is the same as diagram 16, $\pm 15^\circ$. The gasket should be set and tight but not deformed to a rounded or bulbous appearance. If the drain valve was removed reinstall it. Reconnect the wiring. Test the unit per SECTION 7: OPERATIONAL TEST. Check for leaks at the element. Replace the front cover and the HEATING ELEMENT ACCESS cover.

B. PRINTED CIRCUIT REPLACEMENT:

Printed circuit assembly (PCA) removal and replacement must be performed in the sequence described below. Any other method can damage the PCA.

IMPORTANT

The PCA's contain static sensitive devices. Static electricity may damage PCA's. Handle accordingly.

Disconnect power from the unit. Note and tag the positions of all wires that plug into the printed circuit assembly mounted relays. Remove all the wires from the relays. When removing these wires, pull on the connector, not the wire. Note the blue wire connected to the shortest of the triple pronged water level probe. Disconnect all three wires from the water level probe. Disconnect all seven standoffs by pinching the tops. When it is completely disconnected, it may be lifted out of the enclosure. See diagram 24. To install the board, reverse this procedure. Test the unit per SECTION 7: OPERATIONAL TEST.

IMPORTANT

The blue wire connected to "L" and "P3" on the PCA must be connected to the shortest of the three level probes.

C. WATER SOLENOID REPLACEMENT:

Disconnect power from the unit. Turn the water supply OFF. Disconnect the water supply from the water solenoid valve. Remove the front cover. Remove the two blue wires from the water solenoid valve. Rotate the self-tightening hose clamp so it can be loosened with a pair of pliers. Squeeze the clamp and move it down towards the shelf and off the valve outlet tube. Remove the two 1/4" - 20 hex head bolts and lock washers that attach the valve to the chassis. Pull the valve off the rubber fill hose. To install the valve, reverse these instructions. Test the unit per SECTION 7: OPERATIONAL TEST.

D. LEVEL PROBE REPLACEMENT:

Disconnect power from the unit. Remove the front cover. Note where the blue wire is connected to the triple pronged water level probe. Disconnect all three wires from the water level probe. Using a 1-1/4" box wrench, remove the level probe. Install a new level probe. Use Teflon Tape on threads of probe if required. Tighten until the bottom of the plastic nut is 1/8" to 3/8" inch above the top of the port. See diagram 17. Reattach the three wires. Test the unit per SECTION 7: OPERATIONAL TEST.

IMPORTANT

The blue wire connected to "L" and "P3" on the PCA must be connected to the shortest of the three level probes.

IMPORTANT

The level probe may be extremely tight. Damage to the insulation or chassis may result unless the tank is properly blocked or supported during probe removal or installation. It may be necessary to completely disconnect and disassemble the generator.

WARNING

All electrical supplies should be disconnected when servicing generator.

Electrical Shock Hazard. PCA's have exposed 208 / 240 VAC on them. Disconnect 208 / 240 VAC power to the generator before servicing.

The relays may be damaged if the correct orientation of the connectors is not observed. See diagram 23.

DIAGRAM 19

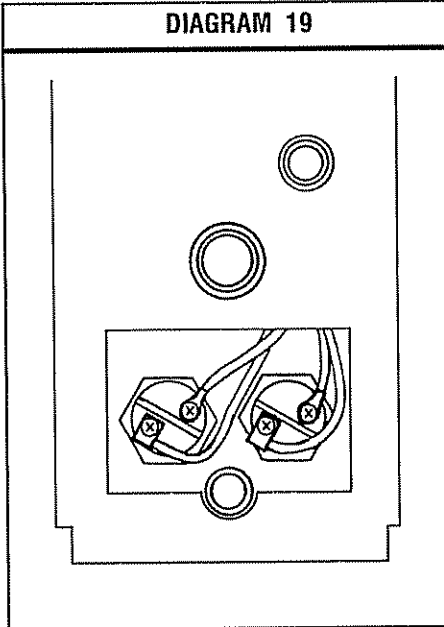

DIAGRAM 20

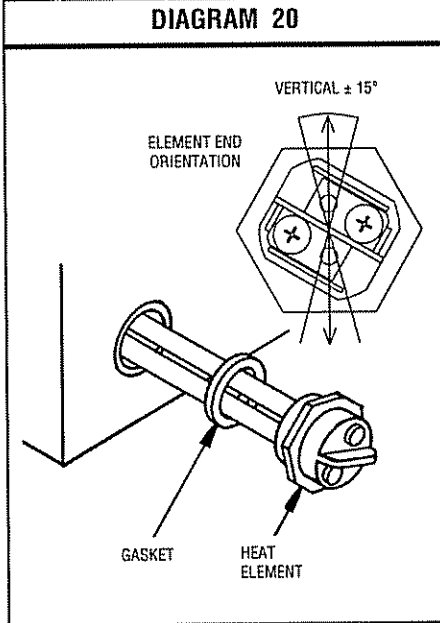

DIAGRAM 21

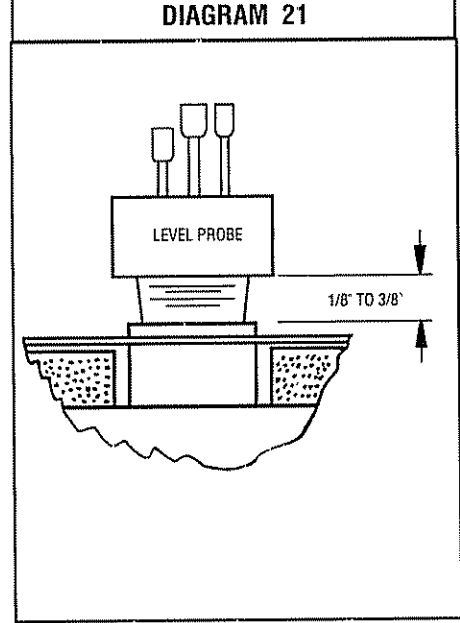

DIAGRAM 22

This diagram intentionally left blank.

DIAGRAM 23

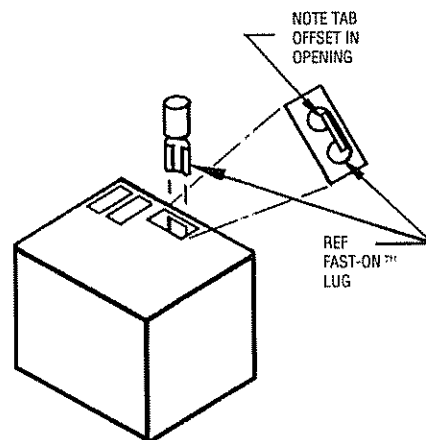
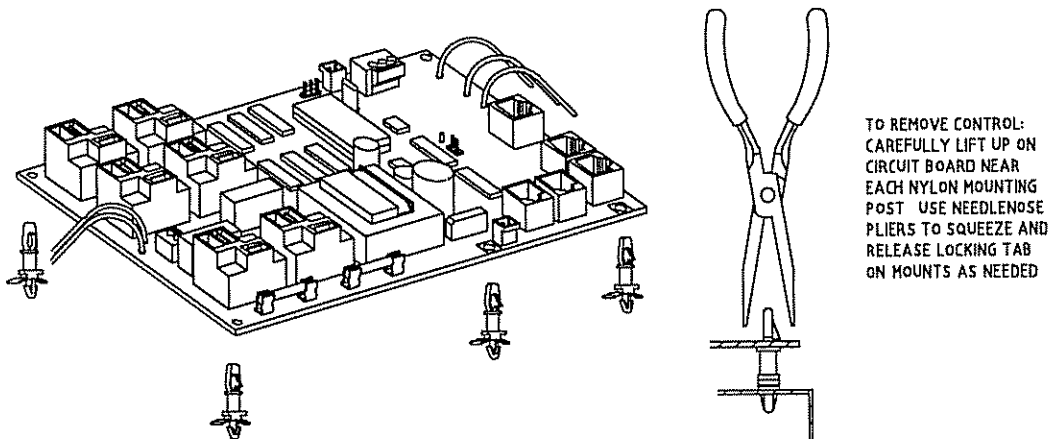

DIAGRAM 24



SECTION 9: OPTIONAL MODIFICATIONS

The 3K Generator design may incorporate several modification options. Options such as automatic tank draining and others are available. Please call the AMEREC Service Department at 1-800-331-0349 for instructions and availability of these options.

SECTION: 10 TROUBLE SHOOTING GUIDE

There are no user serviceable parts in the Generator. All repair should be performed by a qualified service person. For additional assistance or the factory authorized service person nearest you call the AMEREC Service Department at 1-800-331-0349. The Trouble Shooting Guide below is meant as a general aid only. Follow ACTION TO BE TAKEN in order until the problem is resolved. Where replacements or repairs are indicated, see the appropriate paragraph of SECTION: 8 SERVICE

SYMPTOMS	PROBABLE CAUSES	ACTION TO BE TAKEN
Control won't turn "ON" (Control light off)	Improper power supplied (no power) or Control improperly connected or "PCA" printed circuit assembly is faulty or Control cable is faulty or Control is faulty	<ol style="list-style-type: none"> 1 a Make sure circuit breaker is "ON" b Using a voltmeter, check the voltage across the two fuses on the "PCA" printed circuit assembly. Voltage should be 208V c Check fuses on the PCA. If fuse(s) are blown, replace with Buss# MDL 15/100 or equivalent fuse. If the fuse blows again - call AMEREC's Service Department. 2 Check control(s) installed per Section 6-5 3 Replace PCA printed circuit assembly - call AMEREC's Service Department. 4 Replace control cable - call AMEREC's Service Department. 5 Replace the control - Call AMEREC's Service Department.
Control "OFF" (Control light off) Water won't shut off and runs out of the steam head	Water solenoid valve is stuck open or "PCA" printed circuit assembly is faulty	<ol style="list-style-type: none"> 1 Turn off power to the generator. If the water stops, go to step 3 2 a Remove the water solenoid valve, disassemble, clean, re-assemble, and check for proper operation b Replace valve - call AMEREC's Service Department 3 Replace the "PCA" printed circuit assembly - call AMEREC's Service Department
Control "ON" (Control light on) Water won't shut off and runs out of the steam head	"PCA" printed circuit assembly is faulty or Connection between the blue wire and the water level probe is faulty or Unit improperly grounded	<ol style="list-style-type: none"> 1 Check that the blue wire is properly attached to the water level probe 2 Check that the generator is properly grounded 3 Check the green ground wires to the "PCA" printed circuit assembly 4 Replace the "PCA" printed circuit assembly - call AMEREC's Service Department.
Control "ON" (Control light on), Tank drained Unit won't fill	No water supplied (turned off?) or Plugged water solenoid valve or Water solenoid valve is faulty or "PCA" printed circuit assembly is faulty or Level probe is faulty	<ol style="list-style-type: none"> 1 Check for proper water supply (Supply valve "on") Check for closed drain valve 2 Remove the blue wire from the level probe. If the unit fills, clean or replace the level probe 3 Reconnect the shortest wire to the level probe. At the water valve solenoid, slide back the blue connector enough to get the voltmeter probes on the solenoid terminals. Measure the voltage across the solenoid terminals. If it is not 208V, replace the printed circuit assembly. If 208V is found proceed with steps 4 & 5 4 Remove water solenoid valve; disassemble, clean, reassemble, and check for proper operation 5 Replace the water solenoid valve - call AMEREC's Service Department.

SECTION 10: TROUBLE SHOOTING GUIDE cont.

SYMPTOMS	PROBABLE CAUSES	ACTION TO BE TAKEN
<p>Control "ON" (Control light on) Unit won't steam</p> <p>Note: Steam lit steadily on K30 or Time/Temp properly displayed on K60</p>	<p>Unit has not filled completely or Heating elements burnt out. or Level probe faulty or "PCA" printed circuit assembly is faulty</p>	<p>1 a Push the control "OFF" b Open the drain valve allowing tank to drain completely c Close the drain valve d Push the control "ON" e Unit will begin filling, listen for a click noise. Within 20 seconds after click noise is heard, the water fill will shut off. This will indicate the tank is full. Go to step 4. If the tank does not fill - See SYMPTOMS: "Unit won't fill up"</p> <p>2 If the tank filled but the relay click was not heard, temporarily ground the two long probes. If the click is heard as each probe is grounded, replace the level probe. If the click is not heard replace the "PCA" printed circuit assembly</p> <p>3 After it has been determined that the tank has filled and the click noise was heard, remove the heating element access panel. Using a voltmeter, check the voltage between the two wires on each heating element - the voltage should be 208V. If proper voltage is found call the factory for replacement heating elements. If no voltage is found - check wiring diagram - call AMEREC's Service Department.</p>
<p>Control "ON" K60 Control displays "E001"</p>	<p>Temperature sensor not connected</p>	<p>1 Check that the sensor cable is connected to J4 on the "PCA" printed circuit assembly 2 Check the cable connection to the temperature sensor. 3 Replace sensor and/or cable - call AMEREC's Service Department.</p>
<p>Control "ON" K60 Control displays "E002"</p>	<p>Temperature sensor or cable shorted</p>	<p>1 Check sensor cable for damage from nail/staple puncture 2 Check sensor cable ends for frayed/exposed wire strands 3 Replace sensor and/or cable - call AMEREC's Service Department.</p>
<p>Control "ON" K60 Control displays "E003"</p>	<p>Control improperly connected</p>	<p>1 Check that the control cable is properly plugged in at the control and at the generator. K60 to primary SK3 connector on the PCA. Turn off power supply, wait one (1) minute then turn back on. Check for proper operation. If "E003" is still displayed turn off power supply, remove control cable and plug into secondary SK4 connector. Turn on power supply and check for proper operation. If "E003" is still displayed turn off power and call AMEREC's Service Department.</p>
<p>Control "ON" K60 Control displays ">>>"</p>	<p>Steambath temperature over 132 ° or Sensor/cable faulty</p>	<p>1 If bath is too hot, shut off circuit breaker and call AMEREC's Service Department. 2 Treat as "E002" fault above</p>
<p>Control "ON" K30 light blinking</p>	<p>Control improperly connected or Sensor/cable faulty or Control faulty</p>	<p>1 Check that the control cable is properly plugged in at the control and at the generator. K30 to primary SK1 connector on the PCA. Turn off power supply, wait one (1) minute then turn back on. Check for proper operation. If K30 is still "blinking", turn off power supply and call AMEREC's Service Department. 2 Check sensor/cable as with K60 "E001" and "E002" 3 Replace K30 Control - call AMEREC's Service Department.</p>
<p>Control won't turn "OFF" (Control light off)</p>	<p>Control is faulty</p>	<p>1 Replace the control - call AMEREC's Service Department.</p>
<p>Control "OFF" Unit won't shut off</p>	<p>"PCA" printed circuit assembly is faulty</p>	<p>1 Turn off the power to the generator, replace printed circuit assembly - call AMEREC's Service Department.</p>
<p>Water continually splutters out of steam head</p>	<p>Foaming contaminants in the water.</p>	<p>1 Flush tank 3 times. See section 8, flushing procedure. 2 Call AMEREC's Service Department.</p>
<p>Unable to adjust Time or Temp setting with K60</p>	<p>Control faulty or "PCA" printed circuit assembly is faulty</p>	<p>1 Replace control - call AMEREC's Service Department. 2 Replace PCA - call AMEREC's Service Department.</p>

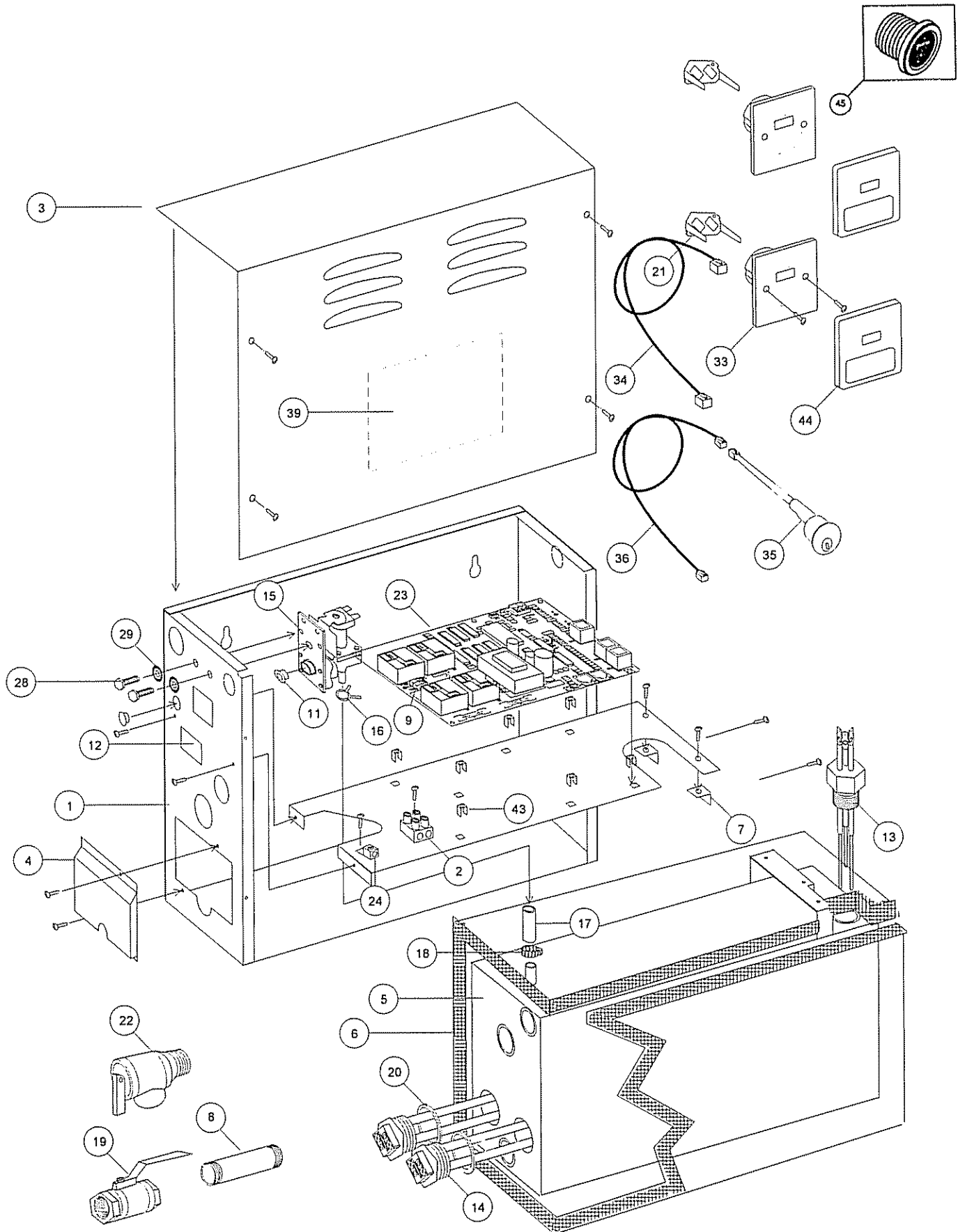

continued 

PARTS LIST

PARTS AND / OR RETURNS:

NUMBE- R	PART NAME	DESCRIPTION
1	FRAME	CHASSIS
2	TERMINAL	POWER INPUT TERMINAL BLOCK
3	COVER	FRONT WITH WD LABEL
4	COVER	ELEMENT ACCESS
5	TANK	TWO ELEMENTS
6	INSULATION	BLANKET
7	BRACKET	L BRACKET
8	NIPPLE	DRAIN NIPPLE
9	TERMINAL	OPTIONAL AUTO FLUSH TERMINAL BLOCK
11	CAP	CAP, THREAD PROTECTOR
12	LABEL	UL RATING
13	PROBE	TRIPLE LEVEL
14	ELEMENT	REPLACEABLE ELEMENT
15	VALVE	WATER INLET
16	CLAMP	SELF-TIGHTENING
17	HOSE	WATER
18	CLAMP	AUGER
19	VALVE	MANUAL DRAIN
20	GASKET	ELEMENT
21	BRACKET	MOUNTING BRACKET
22	VALVE	PRESSURE RELIEF
23	PCA	"BLACK" PRINTED CIRCUIT ASSEMBLY, 3K
24	LUG	GROUND
28	BOLT	1/4-20 x 1/2"
29	WASHER	1/4" LOCK
33	CONTROL HOUSING	CONTROL HOUSING
34	CABLE	CONTROL CABLE
35	SENSOR	TEMPERATURE SENSOR
36	CABLE	TEMPERATURE SENSOR CABLE
37	STEAM HEAD	DISPERSION HEAD (NOT SHOWN)
38	PLACARD	SAFETY (NOT SHOWN)
39	LABEL	WIRE DIAGRAM
40	FUSES	15/100 SLO-BLO (NOT SHOWN)
41	FUSES	3A SLO-BLO (NOT SHOWN)
43	STANDOFF	STAND OFF
44	COVERPLATE	DECORATIVE CONTROL COVER PLATE
45	CONTROL	R30i CONTROL

• For assistance or parts ordering, please contact your local AMEREC Dealer or AMEREC at 1-800-331-0349. Please help us to serve you better by:

1. Identifying the problem by using the troubleshooting guide in this manual.

2. Read Number 12, the UL Ratings Label, to obtain your unit's model and code number.

• When ordering parts, please provide the number, description and quantity needed. When ordering wires or wire assemblies, please describe the wires by color, location and / or their connection points.

• Do not return any material to AMEREC without first contacting AMEREC for a Return Authorization Number. Freight must be prepaid to AMEREC.

**3 PHASE STEAM GENERATOR WIRING DIAGRAM
DIGITAL CONTROL AND MASTER OPTION**

NOTE: DIGITAL SYSTEM OPERATION REQUIRES
A ROOM TEMPERATURE SENSOR PLUS
MINIMUM (1) DIGITAL ON/OFF OR (1) DIGITAL TIME/TEMP CONTROL

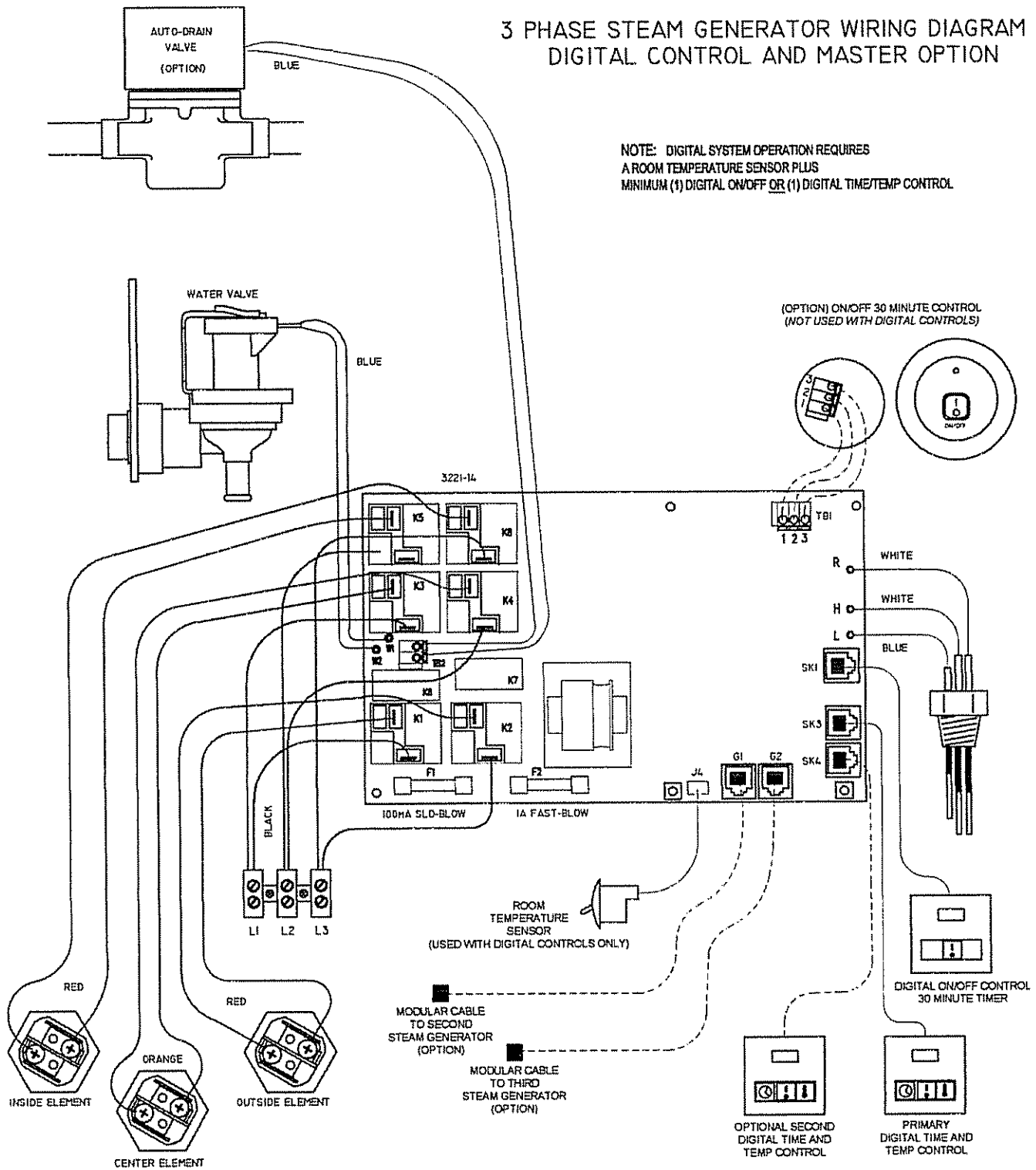

4176-106A2 22 MAR 02

AMEREC
SAUNA & STEAM
P.O. Box 2258, Woodinville WA 98072
425-951-1120 Fax: 425-951-1130
email address: amerec@amerec.com

continued