

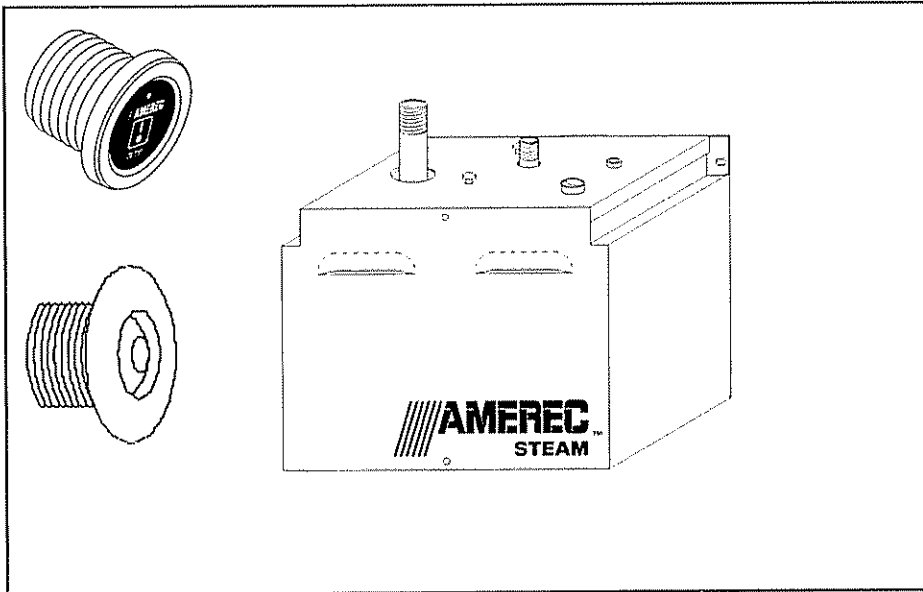

AV Series Installation and Service Instructions



AMEREC STEAMBATH GENERATOR

(MODEL: AV2, 2KW/230 VOLT)

SAVE THESE INSTRUCTIONS

READ ALL INSTRUCTIONS CAREFULLY BEFORE INSTALLATION.

POST "WARNING" LABEL OUTSIDE STEAMBATH FOR SAFETY WARNINGS. REQUIRED POSTING ON DOOR OF STEAM ROOM OR ADJACENT TO DOOR FOR ALL COMMERCIAL INSTALLATIONS.

SECTION 1: GENERAL INFORMATION

AMEREC steam generators are listed by Underwriters Laboratories. The steam generators come assembled and ready for installation. Check that the size and rating of the generator is suitable for your application.

IMPORTANT

An exhaust fan installed outside the steam room is strongly recommended to remove excess steam from the bathroom or shower area.

WARNING

Electrical grounding is required on all AMEREC steambath generators.

All electrical supplies should be disconnected when servicing generator.

All wiring must be installed by a licensed electrical contractor in accordance with local and national codes.

All plumbing must be installed by a licensed plumber in accordance with all applicable local and national codes.

AV series generators are for indoor use only.

AV series generators are not for space heating purposes.

Be certain that steambath enclosures are properly sealed to avoid water damage from escaping steam. It is recommended that 100% silicone caulk be used to seal all pipes and fittings. Steam must be prevented from escaping into the wall cavity.

Never shut off the water to a steam generator that is in use.

For Residential use only in Acrylic or Fiberglass Enclosures rated for Steam.

WARNING

REDUCE THE RISK OF OVERHEATING AND SCALDING

- Exit immediately if uncomfortable, dizzy or sleepy. Staying too long in a heated area is capable of causing overheating.
- Supervise children at all times.
- Check with a doctor before use if pregnant, diabetic, in poor health or under medical care.
- Breathing heated air in conjunction with consumption of alcohol, drugs or medication is capable of causing unconsciousness.

CAUTION! Do not contact steam head. Stay at least 12" away from hot steam escaping from the steam outlet.

REDUCE THE RISK OF SLIPPING AND FALL INJURY

Use care when entering or exiting the steam room. Foot may be slippery.

NOTE: For additional safety instructions, see owner's manual.



IMPORTANT SAFETY INSTRUCTIONS

1. READ AND FOLLOW ALL INSTRUCTIONS.
2. WARNING - To reduce the risk of injury, do not permit children to use this product unless they are closely supervised at all times.
3. WARNING - To reduce the risk of injury:
 - a. The wet surfaces of steam enclosures may be slippery. Use care when entering or leaving.
 - b. The steam head is hot. Do not touch the steam head and avoid the steam near the steam head.
 - c. Prolonged use of the steam system can raise excessively the internal human body temperature and impair the body's ability to regulate its internal temperature (hyperthermia). Limit your use of steam to 10 - 15 minutes until you are certain of your body's reaction.
 - d. Excessive temperatures have a high potential for causing fetal damage during the early months of pregnancy. Pregnant or possibly pregnant women should consult a physician regarding correct exposure.
 - e. Obese persons and persons with a history of heart disease, low or high blood pressure, circulatory system problems, or diabetes should consult a physician before using a steambath.
 - f. Persons using medication should consult a physician before using a steambath since some medication may induce drowsiness while other medications may affect heart rate, blood pressure and circulation.
4. WARNING - Hyperthermia occurs when the internal temperature of the body reaches a level several degrees above the normal body temperature of 98.6 degrees F. The symptoms of hyperthermia include an increase in the internal temperature of the body, dizziness, lethargy, drowsiness and fainting. The effect of hyperthermia include:
 - a. Failure to perceive heat:
 - b. Failure to recognize the need to exit the steambath:
 - c. Unawareness of impending risk:
 - d. Fetal damage in pregnant women:
 - e. Physical inability to exit the steambath: and
 - f. Unconsciousness.

WARNING - The use of alcohol, drugs or medication can greatly increase the risk of hyperthermia.

SAVE THESE INSTRUCTIONS

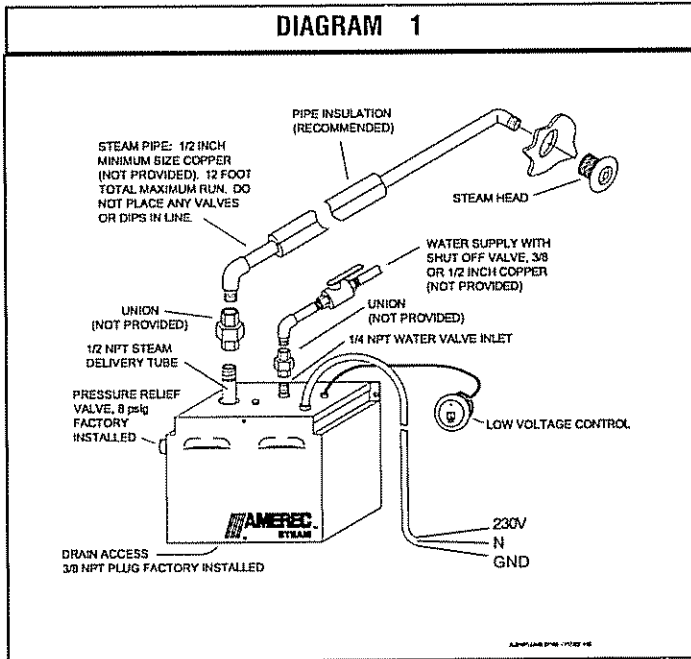

WARNING

*Do not mount outdoors.
Protect from freezing.*

*Unit must be located as to allow
access for service.*

*The generator will not operate
properly, unless it is mounted level
with the arrows pointed up.*

SECTION 2: SELECT MOUNTING LOCATION

The AMEREC steam generator has been carefully designed for ease of installation. It can be hung on a wall or sit on its base. The best mounting location will satisfy all or most of the following:

1. The steam line should slope to allow condensation to drain. Condensation should drain into the steam generator.
2. The steam line should be less than twelve (12) feet long. Ten (10) feet is preferred. Steam lines over twelve feet long should be insulated.
3. The mounting location should minimize the number of bends and elbows in the steam line.
4. The steam line should enter the steam room at least 12" above the floor or at least 6" above a tub rim or ledge.
5. The generator should be installed in a dry, well ventilated area. Suggested locations are under a vanity, in a closet, attic, crawl space or basement.
6. The location should provide clearance for service and element removal.
7. The location should allow the Generator's tank to be drained on a routine basis.

SECTION 3: MOUNTING THE GENERATOR

Wall Mounting:

1. Note the location of the mounting holes on the back of the generator. The screws must set directly into studs or equivalent supports.

Floor Mounting:

1. The generator must be restrained from moving. Normally the piping will provide adequate support. If not, additional support must be provided.
2. All floor installed generators must have provision for routine draining of the tank.

SECTION 4: STEAMHEAD INSTALLATION

1. The steamhead mounts through a 2" hole in the Acrylic Shower Enclosure. The steamhead should be mounted a minimum of 12" from the floor or 6" above a tub rim in a location where it will not present a scald hazard to the bather in their normal seated position.
2. A 1/2" male threaded fitting should be centered to align with the 2" diameter hole in the enclosure and be stubbed out 1-1/2" behind the finished inside surface of the shower enclosure. The steamhead housing mounts to a 1"x1/2" slip to threaded PVC fitting provided.

Test the steamhead fit prior to applying PVC adhesive to permanently attach the steamhead housing and slip fitting. Some play in the fit is available by controlling how tight the slip fitting is attached to either the steamhead housing or 1/2" male threaded fitting, (if required the slip fitting may also be cut shorter). Apply silicone adhesive to the back of the steamhead housing to seal the enclosure once the fit is verified.
(see diagrams 2,3,& 4)



DIAGRAM 2

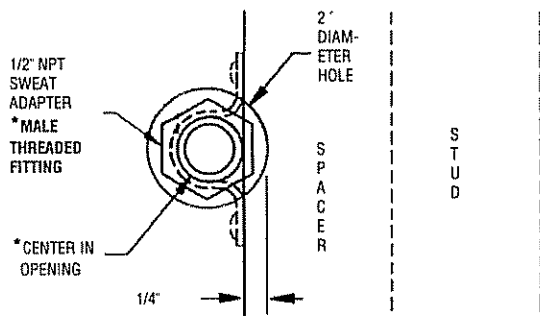

* MUST ALIGN WITH 2" STEAM OUTLET HOLE IN ACRYLIC ENCLOSURE

DIAGRAM 3

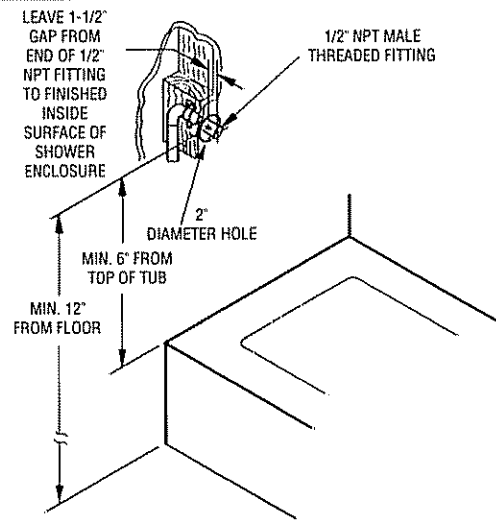

DIAGRAM 4

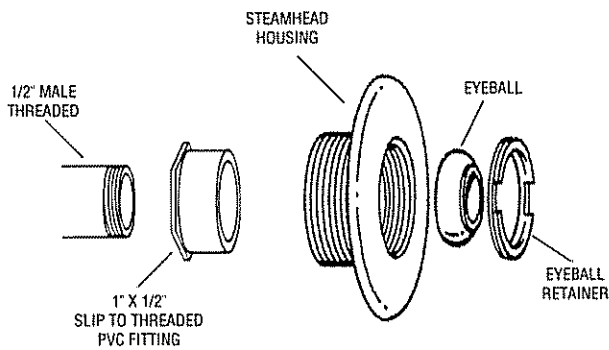
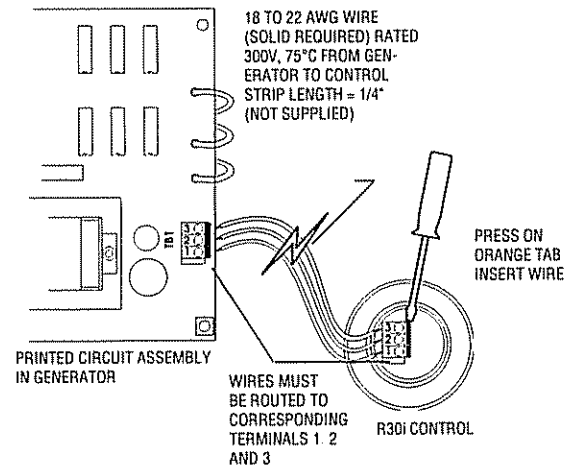

DIAGRAM 5



SPECIFICATIONS

MAX. CAPACITY RATING	AVAILABLE SIZES	MODEL NUMBER	DIMENSIONS LxWxH	DRY WEIGHT	WEIGHT FILLED WITH WATER	PACKAGED SHIPPING WEIGHT
80 Cubic Ft	2kW	AV2	9-1/4" x 4"x 7-1/2"	2.5 lbs (1.1 kg)	3 lbs. (1.4 kg)	3 lbs. (1.4 kg)

SECTION 5: PLUMBING INSTRUCTIONS**IMPORTANT**

Maximum recommend input water pressure not to exceed 100 PSI

Minerals in the water or poor water quality can shorten the life of the steam generator or cause erratic operation if the tank is not drained regularly. Drain the tank frequently

Guard against possible contact with hot steam pipes and other plumbing

Maximum run of the steam pipe is 12 feet. The steam pipe should be insulated. This will reduce condensation in the steam line and will increase efficiency. Use copper and brass pipe and fittings, 1/2 inch minimum, or 3/4" silicone hose with protective cover.

Install a **water supply shutoff valve** where it is easily accessible.

The water supply pipe should be attached to cold supply. Do not use a saddle or piercing type connection for the steam unit water supply.

Apply thread compound sparingly to fitting threads such that excess compound does not dislodge and restrict the copper pipes or water valve. Flush lines before making connections to the generator.

When tightening or loosening fittings, **always use a backup wrench to hold the adjacent fitting**.

Caution: Do not install any valves or create restrictions in the steam line. **Do not construct any dips or valleys in the steam line** as condensation will accumulate in these and block the pipe with water. Pitch the steam line such that condensation will run to the steam generator (preferable) or to the steam head.

SECTION 6: ELECTRICAL REQUIREMENTS

The AV operates at 230 VAC at 50 or 60 Hz. Circuit is to be single phase 3-wire (one conductor at line voltage, one neutral conductor and one ground conductor must be provided). Check your local building code for requirements.

Caution: Without proper grounding protection, a system malfunction may cause fatal shock.

WARNING

Do not connect the overpressure device output into the steam line.

Do not connect the drain valve into the steam line.

Do not put a shut off valve in the steam line. Avoid traps and valleys where water could collect and cause a steam blockage. The hot steam line must be insulated against user contact.

Centering the steam pipe is critical in rooms made of plastic, acrylic, resin, fiberglass or similar materials. Allowing the steam pipe to touch materials not rated 212°F or higher will result in damage to these materials.

Do not install the steam head near bench(es) or where steam may spray or where condensation will drip on the user as this will present a scald hazard.

The steam pipe entry and any other entry into the steam room must be caulked to avoid damage caused by steam leakage into the wall.

Draining the tank into the steam room may present a scald hazard and/or damage materials used to construct the steam room.

Electrical shock hazard - Disconnect all electrical power before servicing the generator. All wiring should be installed by a licensed electrical contractor in accordance with local and national codes.

Electrical Shock Hazard! Wire the timer exactly as described. Do not connect any additional wiring or power supplies to the timer or timer terminals in the generator.



SECTION 7: CONTROL INSTALLATION

The low voltage control can be mounted up to 75 feet from the generator either inside or outside the steam room (A 25' cable is provided) String (3) 18 to 22 AWG solid wires from the control location through 1/2" holes in the wall studs or ceiling joists to the generator

Note: 1) Do not staple through or damage wires, 2) Label or color code wires for proper TB1 to control orientation
See diagram

Route control wires through the generator CONTROL WIRING ENTRY and appropriate strain relief. Connect 3 wires to terminal block TB-1 on the printed circuit assembly, as shown in diagram

The low voltage control can be mounted directly to a finished wall either inside or outside the steam room. Using a 1-3/4" hole saw, drill a hole in the finished wall where the control is to be mounted (the control wires should already be roughed-in to this location). Locate the control wires, pull them out through the 1-3/4" hole and plug the 3 wires into the connector on the back of the control housing, as shown in diagram. Run a bead of 100% silicone caulk around the perimeter on the back of the control housing. See diagram. Insert the control into the wall cavity.

THIS LOW VOLTAGE CONTROL CAN BE LOCATED INSIDE OR OUTSIDE THE STEAM ENCLOSURE

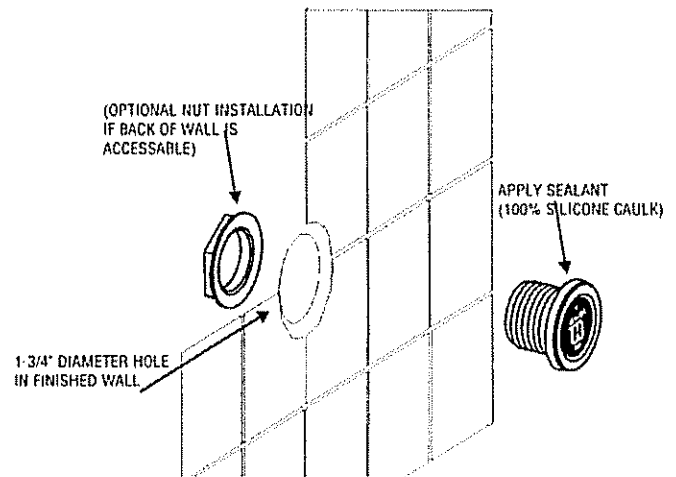
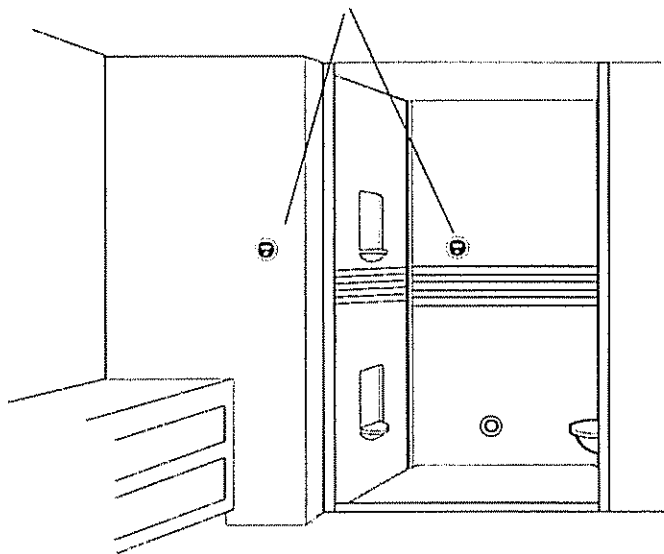

To prepare steam generator:

1. Make certain that **power is disconnected**. Remove cover.
2. Feed wire through hole **A** and connect to **TB1** on the circuit board.
3. Locate strain relief bushing 4" from stripped end of cable jacket with the two connectors. Snap strain relief bushing **B** into hole **A**.
4. Replace cover.

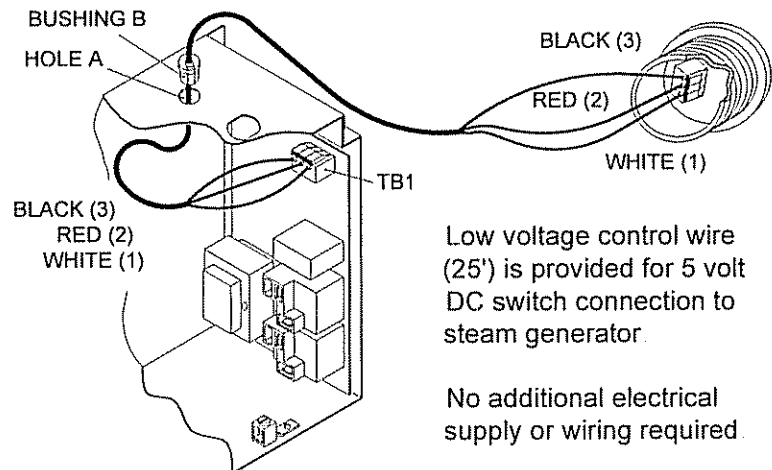

Low voltage control wire (25') is provided for 5 volt DC switch connection to steam generator.

No additional electrical supply or wiring required.

SECTION 8: SERVICE

The AV series generator is the latest in modern steam generator design. The AV steam generator uses a printed circuit assembly to monitor and control all the equipment needed to produce steam. The system has three functions: a timer that controls the length of the steam bath; the operating water level is monitored and controlled; and the heating element is protected by a minimum water level sensor. The element can be removed by removing the tank and unscrewing the element.

Maintenance of the AV generator includes flushing the unit periodically and visually inspecting for water leaks. Whenever the generator is opened all wiring should be inspected for any signs of overheating. All electrical connections should be checked for tightness.

A. ELEMENT REPLACEMENT: Disconnect power from the unit. Drain the tank. Open the front ACCESS cover. Note the wire connections. See diagram. Loosen the tank and remove the element wires. Using a hot water element socket, remove the element. To install a new element, clean the element port and add a light coat of Rectorseal No. 5 pipe thread compound to the element threads. Insert and hand tighten the element. Notice the element end orientation as shown in diagram. Tighten the element until the orientation is the same as diagram, $\pm 15^\circ$. Reconnect the wiring. Test the unit. Check for leaks at the element. Replace the front cover.

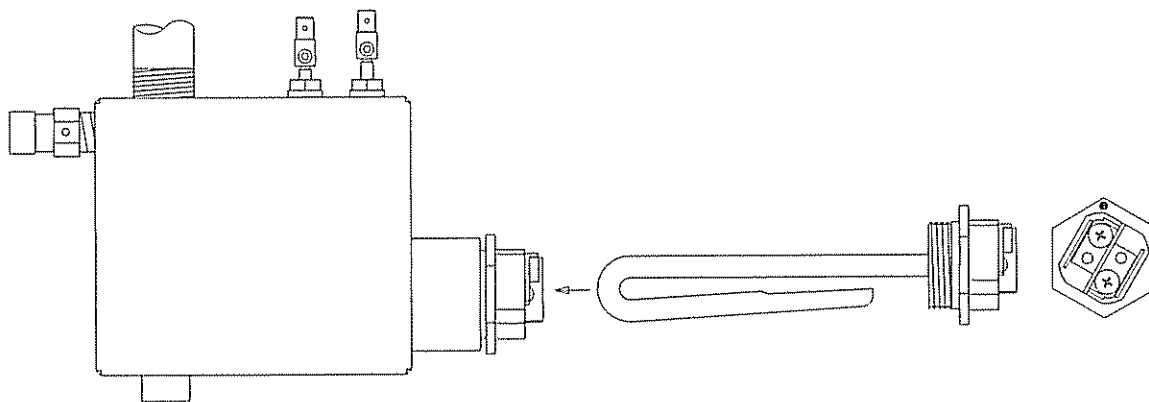

B. PRINTED CIRCUIT REPLACEMENT: Disconnect power from the unit. Remove the front cover. Note where the blue wire is connected to the water level probes. Disconnect the wires from the water level probe. Disconnect the two black wires from the water solenoid and (3) wires connected to TB1. Note and tag the position of all wires that plug into the printed circuit assembly (PCA) mounted relays. Remove and label all the wires from the relays. When removing these wires pull on the connector and not the wire. Four screws through the right side of the unit hold the board in place. Remove all four screws. The printed circuit assembly can now be removed. To install the board reverse this procedure. Test the unit.

IMPORTANT

The blue wire connected to "L" on the PCA must be connected to the highest of the level probes

SECTION 8: SERVICE (continued)

- C. WATER SOLENOID REPLACEMENT:** Disconnect power from the unit. Turn the water supply OFF. Disconnect the water supply from the water solenoid valve. Remove the front cover. Remove the two black wires from the water solenoid valve. Use pliers to carefully twist the hose clamp to loosen, then slide it down the hose. Remove the two 1/4" - 20 hex head bolts and lock washers that attach the valve to the chassis. Pull the valve off the rubber fill hose. To install the valve, reverse these instructions. Test the unit.
- D. LEVEL PROBE REPLACEMENT:** Disconnect power from the unit. Remove the front cover. Note where the blue wire is connected to the water level probe. Disconnect the wire from the water level probe. Using a 7/16" box wrench, remove the level probe. Install a new level probe. Place a small amount of thread seal on the top threads of the level probe. Tighten until the bottom of the plastic nut is against the top of the tank. Reattach the wire. Test the unit.

IMPORTANT

The blue wire connected to "L" on the PCA must be connected to the highest of the level probes

IMPORTANT

The level probe may be extremely tight. Damage to the insulation or chassis may result unless the tank is properly blocked or supported during probe removal or installation. It may be necessary to completely disconnect and disassemble the generator.

SECTION 9: SERVICE

There are no user serviceable parts in the Generator. All repair should be performed by a qualified service person. For additional assistance or the factory authorized service person nearest you call the Service Department at 1-800-331-0349. The Trouble Shooting Guide below is meant as a general aid only. Follow ACTION TO BE TAKEN in order until the problem is resolved. Where replacements or repairs are indicated, see the appropriate paragraph of SERVICE SECTION

SYMPTOMS	PROBABLE CAUSES	ACTION TO BE TAKEN
Control won't turn "ON" (Control light off).	Improper power supplied (no power). Control improperly connected. "PCA" printed circuit assembly is faulty. Control cable is faulty. Control is faulty	<ol style="list-style-type: none"> 1 a Make sure circuit breaker is "ON". b. Using a voltmeter, check the voltage across the two relays on the "PCA" printed circuit assembly. Voltage should be 230V c. Check fuse on the PCA. If fuse is blown, replace with time delay 63MA. If the fuse blows again - call Service Department 2 Check control installed per instructions. 3 Replace PCA printed circuit assembly - call Service Department 4. Replace control cable - call Service Department. 5 Replace the control - call Service Department
Control "OFF" (Control light off) Water won't shut off and runs out of the steam head	Water solenoid valve is stuck open "PCA" printed circuit assembly is faulty	<ol style="list-style-type: none"> 1 Turn off power to the generator. If the water stops, go to step 3 2. a Remove the water solenoid valve. disassemble, clean, re-assemble, and check for proper operation b Replace valve - call Service Department 3. Replace the "PCA" printed circuit assembly - call Service Department.
Control "ON" (Control light on) Water won't shut off and runs out of the steam head	"PCA" printed circuit assembly is faulty Connection between the blue wire and the water level probe is faulty. Unit improperly grounded Unit not level	<ol style="list-style-type: none"> 1. Check that the blue wire is properly attached to the water level probe 2 Check that the generator is properly grounded. 3 Make sure unit is mounted level. 4 Check the green ground wire to the "PCA" printed circuit assembly. 5. Replace the "PCA" printed circuit assembly - call the Service Department
Control "ON" (Control light on), Tank drained. Unit won't fill	No water supplied (turned off?) Plugged water solenoid valve. Water solenoid valve is faulty "PCA" printed circuit assembly is faulty Level probe is faulty	<ol style="list-style-type: none"> 1. Check for proper water supply (Supply valve "on"). Check for closed drain. 2. Remove the blue wire from the level probe. If the unit fills, clean or replace the level probe. 3 Reconnect the blue wire to the level probe. At the water valve solenoid, slide back the wire connectors enough to get the voltmeter probes on the solenoid terminals. Measure the voltage across the solenoid terminals. If it is not 230V replace the printed circuit assembly. If 230V is found proceed with steps 4 & 5 4 Remove water solenoid valve; disassemble, clean, reassemble, and check for proper operation 5 Replace the water solenoid valve - call Service Department.

SECTION 10: TROUBLESHOOTING

SYMPTOMS	PROBABLE CAUSES	ACTION TO BE TAKEN
Control "ON". (Control light on) Unit won't steam.	Unit has not filled completely. Heating element burnt out. Level probe faulty. "PCA" printed circuit assembly is faulty.	<ol style="list-style-type: none"> 1 Check that blue wire is on High probe and white wire is on Low probe. 2 <ol style="list-style-type: none"> a Push the control "OFF". b Remove the drain plug allowing tank to drain completely. c Replace the drain plug. d Push the control "ON". e Unit will begin filling, listen for a click noise. Within 5 seconds after click noise is heard, the water fill will shut off. This will indicate the tank is full. Go to step 3, if the tank does not fill - See SYMPTOMS: "Unit won't fill up". 3 If the tank filled but the relay click was not heard, temporarily ground the white wire/low probe. If the click is heard as probe is grounded, replace the level probe. If the click is not heard replace the "PCA" printed circuit assembly. 4 After it has been determined that the tank has filled and the click noise was heard, use a voltmeter to check the voltage at the element wire's relay connections - the voltage should be 230V. If proper voltage is found call the factory for replacement heating elements. If no voltage is found - check wiring diagram - call Service Department.
Control won't turn "OFF" (Control light off)	Control is faulty.	1 Replace the control - call Service Department.
Control "OFF" Unit won't shut off.	"PCA" printed circuit assembly is faulty.	1 Turn off the power to the generator, replace printed circuit assembly - call Service Department.
Water continually sputters out of steam head.	Foaming contaminants in the water.	<ol style="list-style-type: none"> 1 Flush tank 3 times. 2 Call Service Department.

SECTION 10: WIRING DIAGRAM

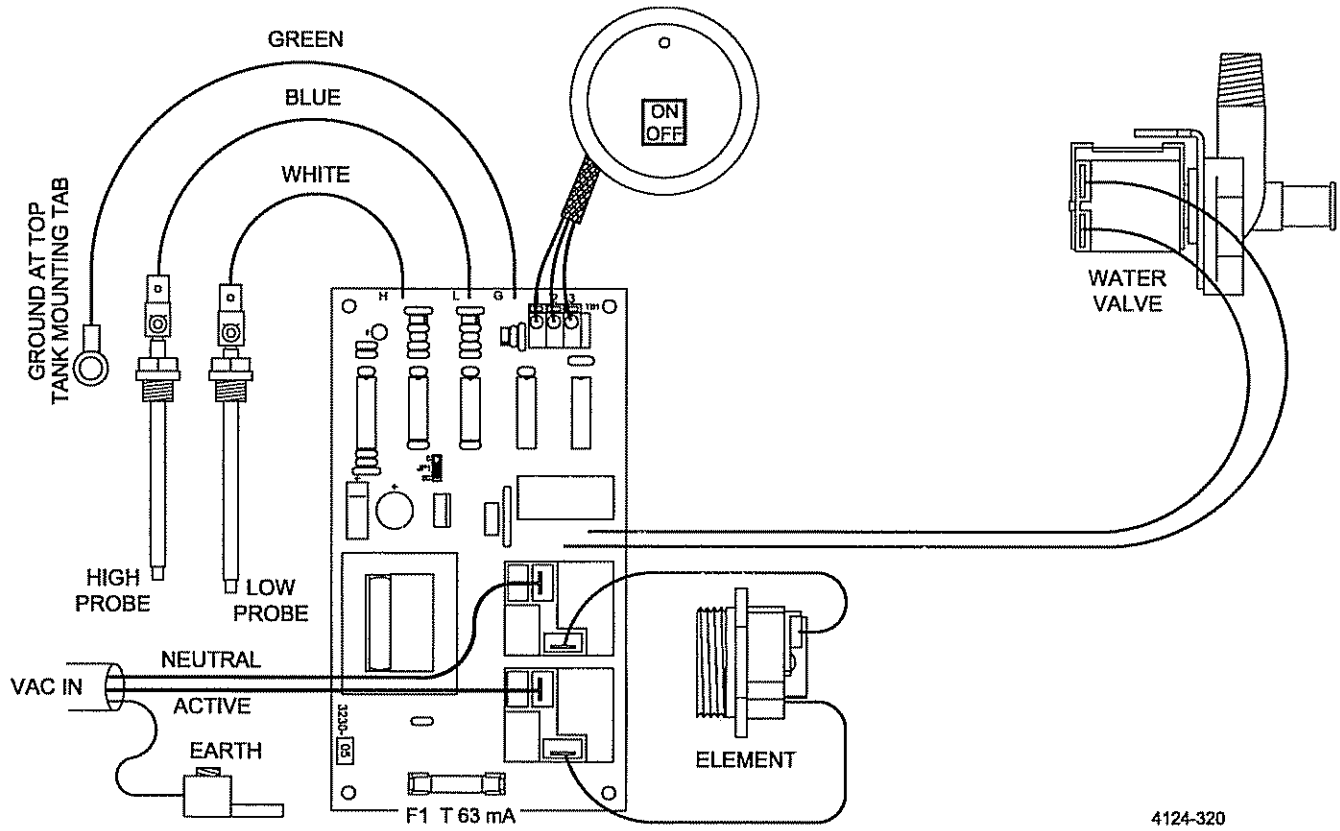

4124-320
02/10/06